

Wrapper Form nipple for SHIME-TOTAKU

Material / วัสดุ

SS, SUS

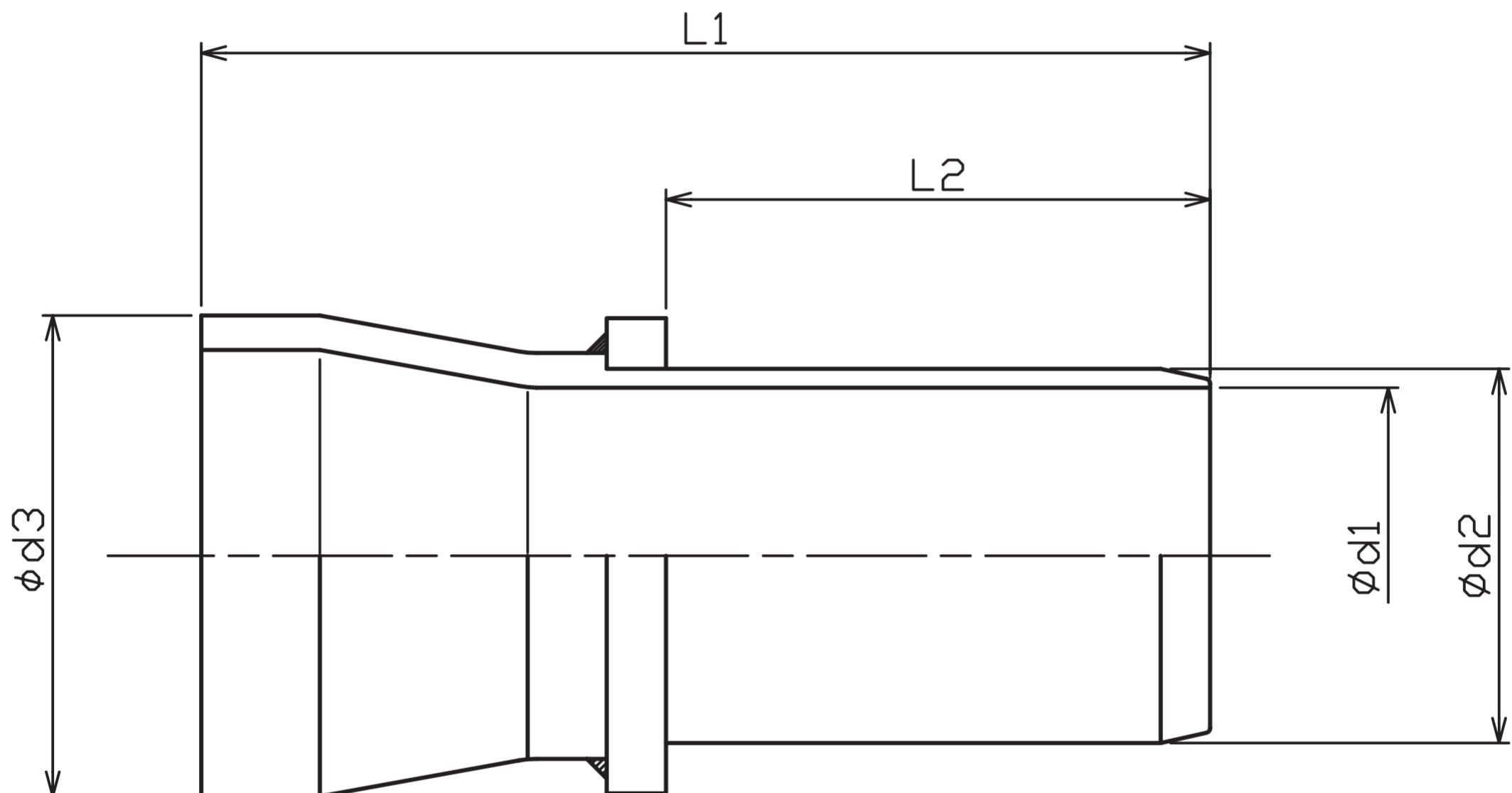

(mm)

Nominal diameter	d1	d2	d3	L1	L2
38	34.0	37.8	48.6	100.0	55
50	43.8 (44.8)	50.5	60.5	111.0	62
65	56.5 (57.5)	63.0	76.3	130.0	72
75	67.9 (70.3)	76.0	89.1	160.0	83
100	93.2 (93.6)	101.0	114.3	178.0	98

※ The value of () is SUS. / ค่าใน () คือ SUS